

2-lite Patio Door

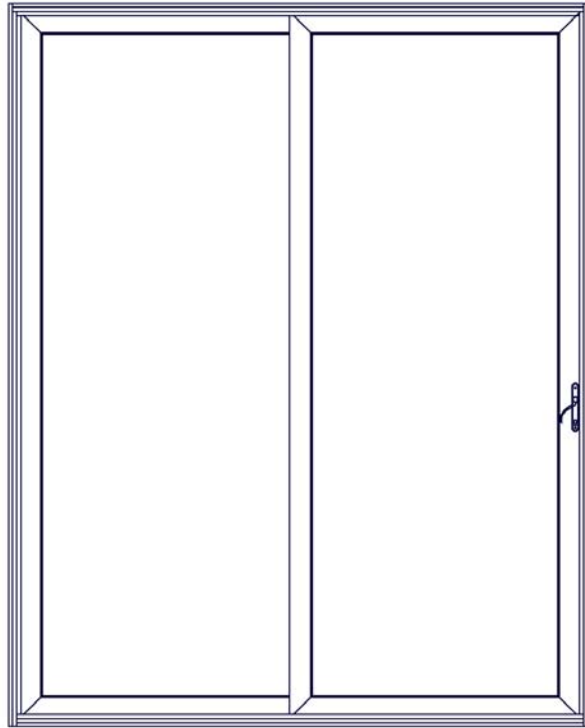

Product A:

Simonton StormBreaker Plus® Vinyl 2-lite Patio Doors

- 6080 – 6068 – 5068 – 8068 – 8080
- 1” Insulating Glass Unit w/Warm-edge Spacer System
- PVB/Tempered
- Sealant Glazed
- Specific hardware must be anchored to the opening. Refer to written installation instructions on AND to applicable drawings sealed by a Florida professional engineer.

STORMBREAKER PLUS AND
FLORIDA CUSTOMERS
PATIO DOOR (EXCLUDES
PROFINISH AND LUMINESS)
RETROFIT ONLY
INSTALLATION PROCEDURE

- NOTES:
A. USE #12 FH WOOD SCREWS WITH 1 1/2" MIN. EMBEDMENT INTO SUBSTRUCTURE IN BOTH TRACKS OF THE PATIO DOOR FRAME TO ANCHOR TO SUBSTRUCTURE. (USE 3/16" DIA. TAPCON TYPE ANCHOR WITH 1 1/4" MIN. EMBEDMENT INTO MASONRY CONSTRUCTION.)

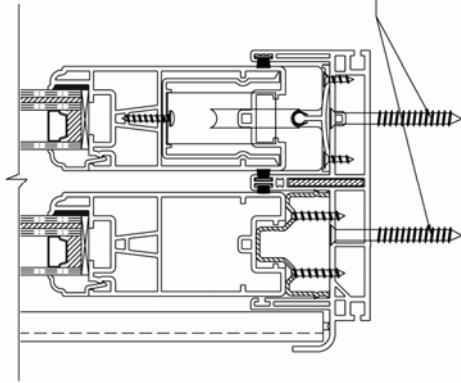

12.0" TYP.
HEAD & SILL

6.0" TYP.

#12 FH WOOD SCREW OR
3/16" Ø TAPCON TYP.

12.0" TYP.

6.0" TYP.

REV.	REVISIONS:	REVISED BY:	DATE:

		SIZE/DRAWING NO.: B INO219	REVZ: —
1 Cochran Avenue Pompano, WV 26415		DRAWN BY: B	DATE: 11/19/08
SCALE: FIT		CHECKED BY: B	DATE: 11/19/08
SERIES: 1 of 1		APPROVED BY: B	DATE: 11-11 PATIO DOOR
TITLE: INSTALLATION INSTRUCTIONS			

Dimensional Tolerances Unless Otherwise Specified	Angles 0° 30 min.
Decimals .X ± .03 .XX ± .01 .XXX ± .005	PERIMETER: ± .005

DISCLOSURE STATEMENT This document is the property of Simonton Windows, which retains all proprietary rights to its subject matter. This document is provided to the recipient on the expressed understanding that it is not to be reproduced, copied, or otherwise used for any purpose other than the repair of goods for anyone other than Simonton Windows without its consent. This restriction does not limit the recipient's right to use the information contained in this document, which is properly obtained from another source.	MATERIAL: FINISH: ALLOY & TEMPER: HEIGHT: SURFACE AREA: FINISH TREATMENT:
---	--

Dimensional Tolerances Unless Otherwise Specified	Angles 0° 30 min.
Decimals .X ± .03 .XX ± .01 .XXX ± .005	PERIMETER: ± .005

DISCLOSURE STATEMENT This document is the property of Simonton Windows, which retains all proprietary rights to its subject matter. This document is provided to the recipient on the expressed understanding that it is not to be reproduced, copied, or otherwise used for any purpose other than the repair of goods for anyone other than Simonton Windows without its consent. This restriction does not limit the recipient's right to use the information contained in this document, which is properly obtained from another source.	MATERIAL: FINISH: ALLOY & TEMPER: HEIGHT: SURFACE AREA: FINISH TREATMENT:
---	--

Dimensional Tolerances Unless Otherwise Specified	Angles 0° 30 min.
Decimals .X ± .03 .XX ± .01 .XXX ± .005	PERIMETER: ± .005

3-lite Patio Door

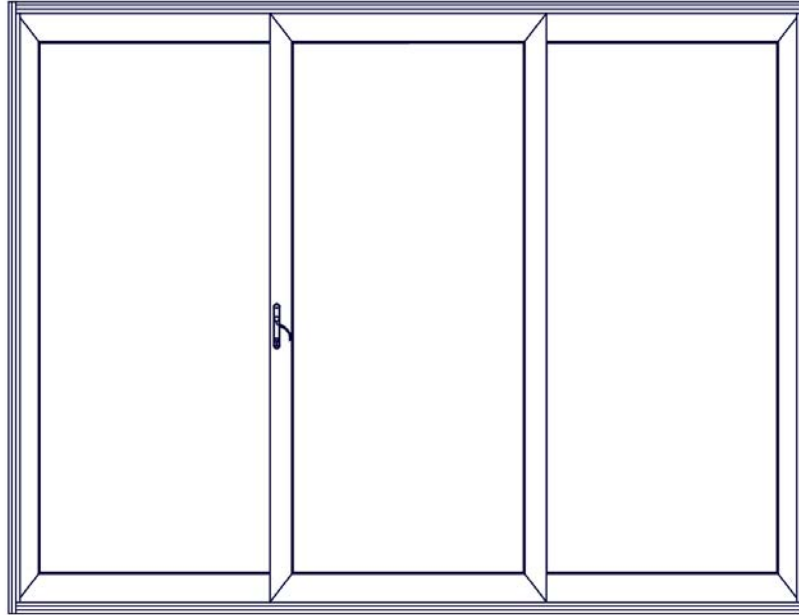

Product :

Simonton StormBreaker Plus® Vinyl 3-lite Patio Doors

- 9068 – 9080 – 12068 – 12080
- 1” Insulating Glass Unit w/Warm-edge Spacer System
- PVB/Tempered
- Sealant Glazed
- Specific hardware must be anchored to the opening. Refer to written installation instructions on AND to applicable drawings sealed by a Florida professional engineer.

STORMBREAKER PLUS AND
FLORIDA CUSTOMERS
3-LITE PATIO DOOR (EXCLUDES
PROFINISH AND LUMINEX)
RETROFIT ONLY
INSTALLATION PROCEDURE

- NOTES:
A. USE #12 FH WOOD SCREWS WITH 1 1/2" MIN. EMBEDMENT INTO SUBSTRUCTURE IN BOTH TRACKS OF THE PATIO DOOR FRAME TO ANCHOR TO SUBSTRUCTURE. (USE 3/16" DIA. TAPCON TYPE ANCHOR WITH 1 1/4" MIN. EMBEDMENT INTO MASONRY CONSTRUCTION.)

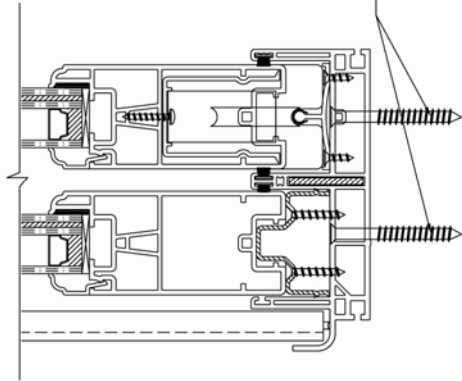
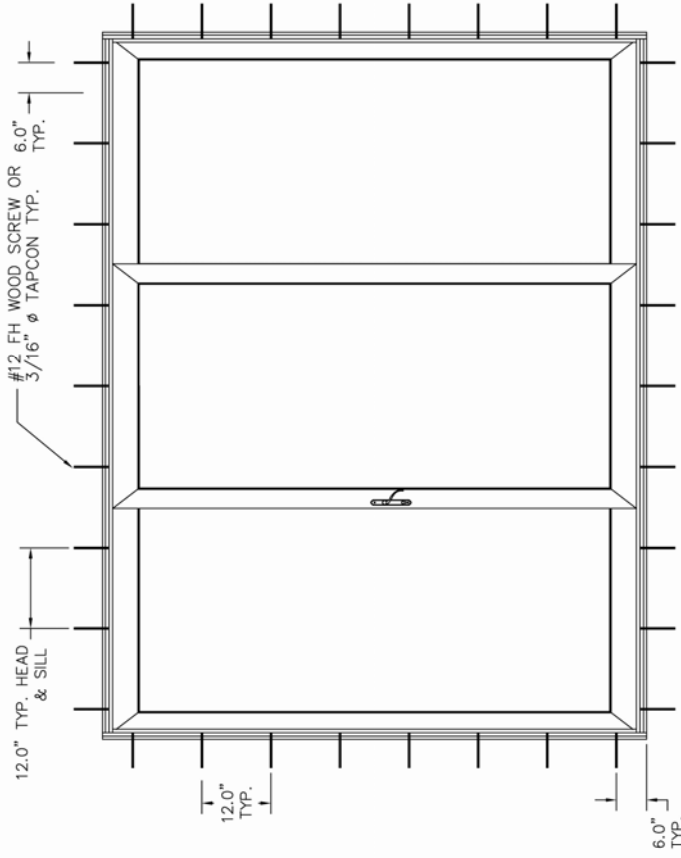

REV.	REVISIONS	REVISED BY:	DATE:
1			
2			
3			
4			

<p>DISCLOSURE STATEMENT This document is proprietary and other rights to its subject matter are reserved. This document is provided to the recipient on the expressed understanding that it is for informational purposes only and is not to be used in conjunction with the design, manufacture or repair of goods for anyone other than Simonton Windows. Simonton Windows and its logo are registered trademarks of Simonton Windows. The recipient's rights to utilize information contained in this document which is properly obtained from another source, is hereby disclaimed.</p>		<p>MATERIAL: RHS FINISH: _____ ALLOY & TEMPER: _____ WEIGHT: _____ SURFACE AREA: _____ FINISH TREATMENT: _____</p>	<p>Dimensional Tolerances Unless Otherwise Specified Decimals Angles X ± .03 XX ± .01 XXX ± .005</p>	<p>SIZE/DRAWING NO.: REV. _____ B INDO220 DRAWN BY: DAVID G. GLENN DATE: 01/18/08 CHECKED BY: DATE: _____ APPROVED BY: DATE: _____</p>
<p>SIMANTON WINDOWS 1 Cochran Avenue Pemberton, WV 26415</p>		<p>SHEETS: 1 of 1 SERIES: FIT SCALE: 1/8" = 1'-0"</p>	<p>TITLE: 11-LITE PATIO DOOR INSTALLATION INSTRUCTIONS</p>	<p>FILE: INDO220</p>