

ANGULAR GEOMETRIC CASING ASSEMBLY INSTRUCTIONS

Item #	Description	Quantity
1	Casing Frame Pieces	Varies with Geometric Shape
2	Adjustable Corner Key – Male Half	Varies with Geometric Shape
3	Adjustable Corner Key – Female Half	Varies with Geometric Shape
4	Screw Pack	Varies with Geometric Shape

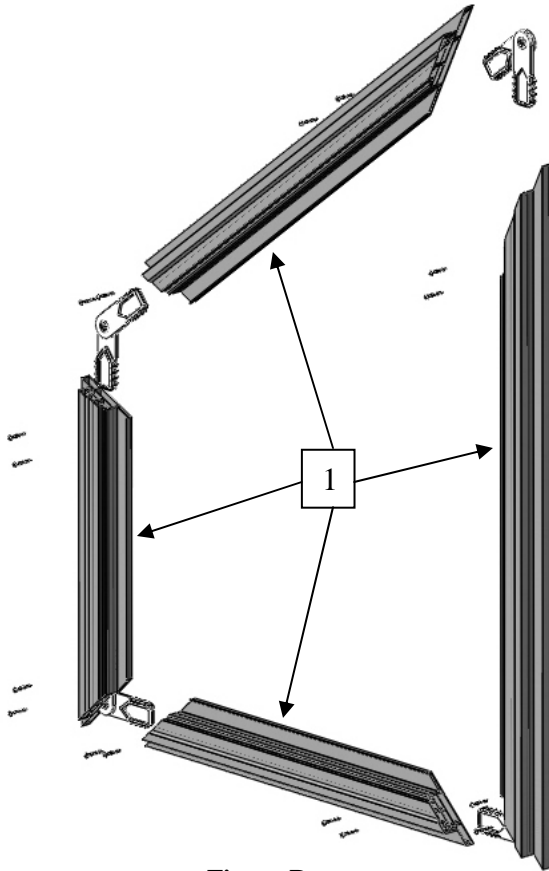

Figure B

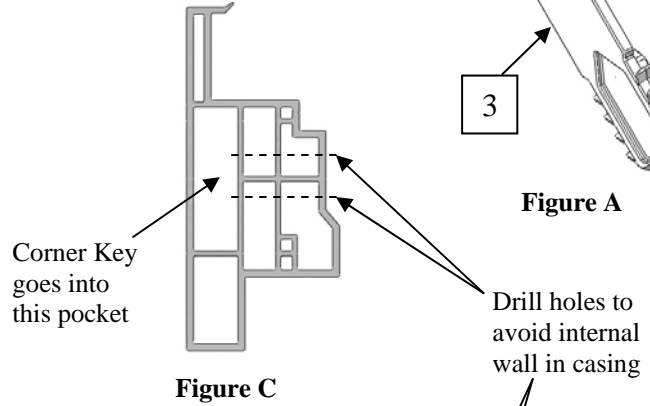

Figure C

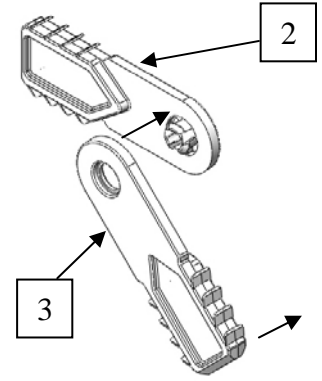

Figure A

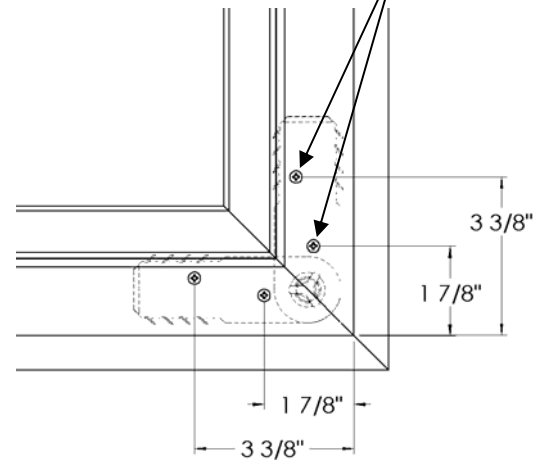

Figure D

IMPORTANT: READ THE INSTRUCTIONS AND FAMILIARIZE YOURSELF WITH THE CASING PARTS AND PIECES BEFORE BEGINNING ASSEMBLY AND INSTALLATION



WARNING: BEFORE PROCEEDING WITH ASSEMBLY AND INSTALLATION, ENSURE THE WINDOW HAS BEEN PROPERLY INSTALLED AND FLASHED.

- Check to see that the components in the table are included
- Snap all pairs of male and female corner key halves together as shown (Fig. A)
- Lay out all frame pieces on a flat surface in the shape that matches the window to which it will be installed
- Insert an assembled corner key into the casing pocket indicated in Fig. C for each frame corner
- Push frame pieces together, making sure all corners are aligned and tight
- Drill 3/32" pilot holes (4 per corner) on the back side in the approximate locations as shown (Figs. C & D)
- Insert 4 screws per corner. To avoid stripping screws out, do not over-tighten