



BAY AND BOW

INSTALLATION INSTRUCTIONS



IMPORTANT: Please read all instructions thoroughly before beginning the installation of the window.

TOOLS NEEDED:

- Tape Measure
- 4' Level
- #2 Phillips Bit (4" in length)
- #3 Phillips Screwdriver (6" in length)
- 1/2" Wrench
- Cordless Screw Gun
- 1/8" Drill Bit (4" in length)
- 3/32" Drill Bit
- Caulk Gun and Color-matched Silicone Caulk

1 Begin by measuring the opening. Measure at three locations: top, middle and bottom or the opening width and right, center, and left of the height. Use the smallest of these measurements to determine the width and height of the Bay/Bow. Also, measure the wall thickness from the inside of the opening to the outside of the exterior materials. Do not remove the old windows or unit until the dimensions of the new Bay/Bow has been verified to fit the opening properly.

2 It is important to remember the Bay or Bow must fit into the opening plumb, level and square, even though the opening may not be any of these. Remove the old windows or unit and prepare the opening, leveling off sill if necessary.

3 Begin by installing both Wall Brackets 12" to 15" above the rough opening using one of the two 1/4" x 3" long, lag screws provided (See Figures #1 - 4). Use the hole in the center of the wall bracket for this lag screw. Keep in mind the roof structure height of the unit.

Note: The cables can be installed at any degree between 15 and 90 degrees from horizontal measured between the cable and the head board (See Figure #2). Wall brackets can be placed as much as 45 degrees to either side of vertical measured from the window hook mounted to the top of the Bay/Bow unit (See Figure #1). This flexibility ensures that the wall bracket can be anchored to a wall stud.

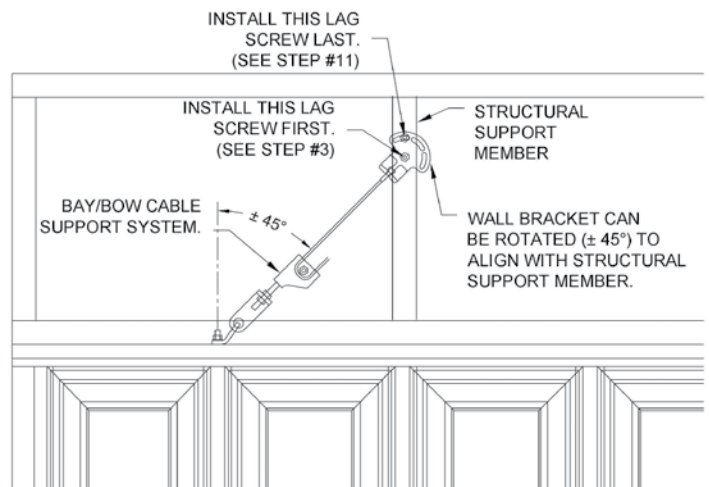

Figure 1: Elevation View Note: A solid, structural mounting surface is required for wall bracket installation. The removal of fiberboard or foam sheathing may be necessary to expose a solid, structural mounting surface at header, second floor sill plate or wall studs.

4 Remove all wooden shipping blocks from the underside of the Bay/Bow.

5 Carefully remove the jamb veneers along the inside of the jambs and save for later (See Figure #5).

6 Caulk along the edges of the rough opening and the sill plate, as well as the F-Channels along the perimeter. Place the unit in the opening and place a support underneath the nose of the Bay/Bow unit. Make sure that Bay/Bow unit is level.

- 7** Using the hardware from the Cable Support System pack, attach the angled Hook Bracket to the Window Hook that is already installed on the 5/16" all-thread at the top of the Bay/Bow unit (See Figure #4). Make sure that the adjustment nut on the main cable support body is in the center of the adjustment thread. **Note: Warranty Requirement. The attached cable system must be used to support the unit from above. Support from above is required. Never remove the all-thread bolts which tie the head and seat boards together.**

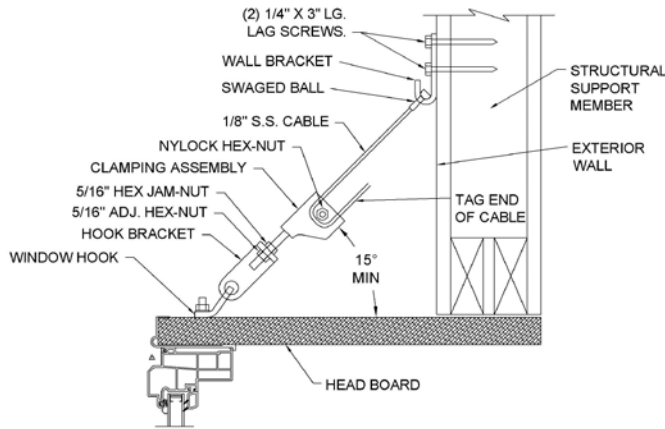

Figure 2: Section View

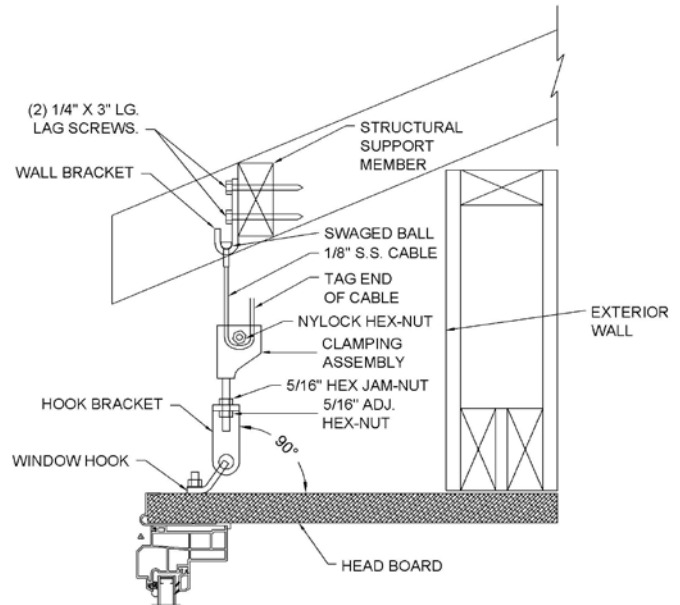

Figure 3: Section View

- 8** Attach the other end of the cable with the swaged ball to the Wall Bracket (See Figure #4).
- 9** Make sure that the clamping insert on the main support assembly is loose enough to allow the cable to be adjusted. Pull on the tag end of the cable to take out any slack in the cable between the window and the wall bracket (See Figure #4).

- 10** Tighten the 1/2" nylon lock nut on the clamping insert to a torque rating of 15 ft* lbs.

- 11** Rotate wall bracket (if necessary) to maintain proper alignment with cable and attach second 1/4 x 3" lag screw in the appropriate slot directly above the center screw to ensure that lag screw is installed in a wall stud or other solid structural mounting member (See Figure #4).

- 12** Repeat steps 7 thru 11 for second cable support.

- 13** Once both cable supports have been installed, remove the support from under the nose of the Bay/Bow unit so that unit is now supported by the cables.

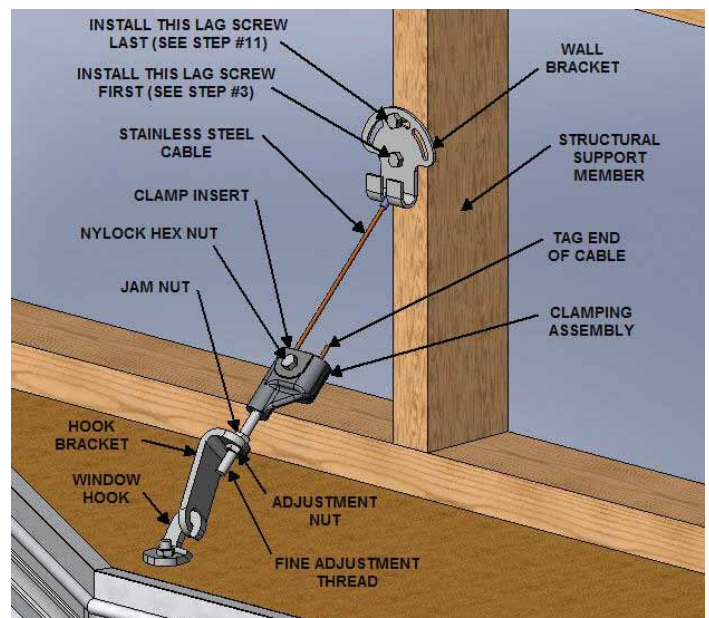

Figure 4

14 To level the Bay/Bow unit, use a wrench to rotate the adjustment nut on the adjustment thread (See Figure #4). Rotate clockwise to raise the nose of the unit, or counter-clockwise to lower the nose of the unit. Adjust each cable support until the unit is level from side to side as well as front to back. Once unit is level tighten the jam nut onto the Hook Bracket.

15 Check for an even reveal between the sash and frame to be certain the weatherstripping is sealing properly in all areas.

16 Once the window is plumb, level and square, insert installation screws through the inside jambs (See Figure #5). The screws should be placed 8" to 12" apart, starting 4" from the top and bottom. Offset screw locations for more support. Shims should be used to establish spacing at anchoring points and should be penetrated by the installation screw. **DO NOT OVER TIGHTEN THE SCREWS**, as this could cause the frame to bow. Do not place screws through the head or seat board. Recheck the sash for proper operation once the screws have been installed.

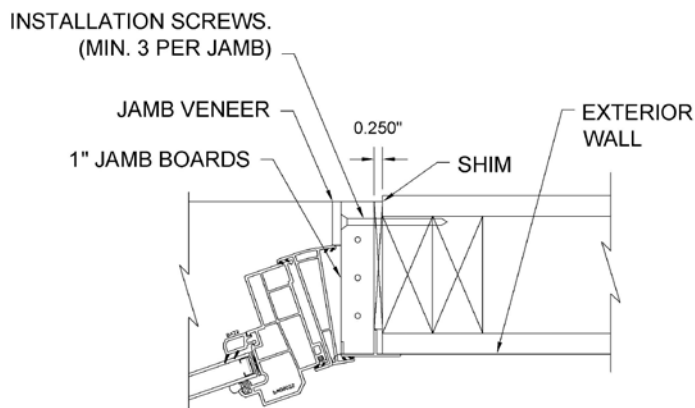

Figure 5: Plan View of Jamb

17 After the installation screws are in place, glue the wood veneer back in place on the inside of the jambs and fill the gap between the jambs and rough opening with insulation.

18 All projected units require a roofing system after installation. The type and style of the roof built will depend on the unit and the architecture of the house. Once the roof is built, use proper grade of sealant and seal the entire perimeter of the unit and the roof. **Note: Warranty Requirement. A roof must be built over the unit after installation. The top of the unit is not designed to prevent water penetration, as manufactured, without a roof.**

19 Finish off the interior of the Bay/Bow unit and install knee braces (optional) on the exterior of the unit. **NOTE: DO NOT USE** water based stains or sealers to finish the interior head and seat board of the Bay/Bow unit. Using water based stains or sealers can cause delamination of the wood veneer. Damage to the head and seat board as a result of using water based stains or sealers is not covered under the product warranty. Interior finishing/sealing should be completed within 30 days of installation.

20 Inspect all exterior sealant joints in case any joints were pulled apart during installation. Reseal any broken seams with the sealant supplied with the unit. **Note: Warranty Requirement. All joints must be checked and caulked with the enclosed caulking compound.**

21 Remember: The homeowner is the final inspector. Clean the window well and remove all debris from the job site. Be sure the homeowner is familiar with the proper operation and all features of the windows.